

BUILDING MATERIAL SPECIFICATIONS

Mortar mix:
Class II mortar mix for brickwork, composed of 1 part Surebuild 42,5N cement (Code: CEM II/B 42,5N) and 6 parts sand in thickness as indicated to brickwork. Surebuild cement is to be manufactured in accordance with SANS 50197-1.

Dampproofing: under surface bed
Gundie® API USB Green 250µm damp proof membrane under concrete surface beds conforming to SANS 952-1:2011 laid with minimum 150 overlaps and sealed with Gunplas sensitive tape.

Screed:
Floor screed mix for concrete surface beds, composed of 1 part Surebuild 42,5N cement (Code: CEM II/B 42,5N) and 3 parts sand in thickness as indicated to concrete surface beds. Surebuild cement is to be manufactured in accordance with SANS 50197-1.

Dampproofing: walls
Gundie® API Brickgrip DPC 250µm damp proof course in solid walls conforming to SANS 952-1:2011 laid with minimum 150mm overlaps.

Plaster:
Plaster mix for rough brick walls, composed of 1 part Surebuild 42,5N cement (Code: CEM II/B 42,5N) and 6 parts sand 10-20mm thick. Surebuild cement is to be manufactured in accordance with SANS 50197-1.

Insulation: in roof space
Min. 135mm thick flexible fibre glass blanket (SABS approved) above ceiling.

Underlay: under concrete roof tiles
Gundie® API UT White 180µm roofing underlay conforming to SANS 952-2:2011, laid with a slight sag and with a minimum overlap of 100mm over timber rafters (at approximately 685mm centres) and fixed concurrent with tiling battens, turned down at eaves.

ROOF ASSEMBLY REQUIREMENTS

MIN. TOTAL R-VALUE OF ROOF ASSEMBLY REQUIRED (CLIMATE ZONE 1) = 3,7
DIRECTION OF HEAT FLOW : UP

R-value of outdoor air film	= 0,03
R-value of conc. roof tiles	= 0,02
R-value of air space (non-reflective)	= 0,18
R-value of plasterboard, 10mm gypsum	= 0,06
R-value of indoor air film (still air)	= 0,11
R-value of added insulation (flexible fibre glass insulation)	= 3,30
TOTAL R-VALUES	= 3,70 = REQUIREMENTS

GLAZING NOTES

- 1) ALL GLAZING TO COMPLY WITH SANS 10400-N:2010 (EDITION 3)
- 2) GLAZING INSTALLATIONS: SEE SECTION 4.2
- 3) GLAZING REQUIREMENTS: SEE SECTION 4.3 & 4.4
- 4) GLAZING TABLE:

	3mm	4mm	5mm	6mm	8mm	10mm	12mm
MONOLITHIC ANNEALED GLASS	0.75m²	1.5m²	2.1m²	3.2m²	4.6m²	6.0m²	6.0m²
TOUGHENED SAFETY GLASS	-	1.9m²	3.0m²	4.5m²	8.0m²	8.0m²	8.0m²

ALL WINDOW PANES BELOW 500mm FROM FINISHED FLOOR LEVEL AND ALL GLASS DOORS TO BE GLAZED WITH TOUGHENED SAFETY GLASS TO SABS 0137

GENERAL NOTES

- 1) ALL WORK TO COMPLY WITH N.B.R. & SANS 10400 BUILDING REGULATIONS (EDITION 3)
- 2) READ FIGURED DIMENSIONS IN PREFERENCE TO SCALING
- 3) ALL LEVELS, HEIGHTS OF PLINTHS, DEPTH OF EXCAVATIONS AND NUMBER OF STEPS TO BE FINALLY CHECKED AND DETERMINED ON SITE
- 4) DPC UNDER ALL WALLS, CILLS AND TO VERTICAL WALLS BELOW GROUND LEVEL
- 5) FLOOR & WALLS IN SHOWER & WALL BEHIND SINK TO BE WATERPROOFED BEFORE TILING
- 6) TRUSSES FIXED WITH ROOF WIRE BUILT 5 COURSES INTO WALL

DRAINAGE NOTES

- 1) ALL BENDS & JUNCTIONS TO BE FITTED WITH IE'S
- 2) WASTE FITTINGS TO HAVE RESEAL TRAPS AND TO BE FULLY ACCESSIBLE
- 3) WASTE PIPES SIZES:- WHB'S = dia 40
- 4) ALL DRAINS UNDER BUILDING TO BE ENCASED IN 100mm CONCRETE

ROOF NOTES

ROOF TO COMPLY WITH SECTION L OF SANS 10400-N:2010 (EDITION 3)

ROOF COVERING	conc. roof tiles	note: no combustible roof component shall penetrate the firewall
FITCH	26 degrees	
PLASTIC UNDERLAY	n/a	
BATTENS	38x38	
TRUSSES	to eng. detail	
TIE BEAMS	152x38	

BLOCK 3 (unit 4)

DRAWING DESCRIPTION

WORKING DWG - PLAN, ELEVATIONS, SECTIONS & DETAILS

PROJECT

PROPOSED NEW TOWNHOUSES ON PARKRAND x17

PJB

pieter bezuidenhout
architect
reg. no. 7477

dwg. no.
4390 - b.3

7 alice avenue
comet
boksburg

p o box 25820
east rand
1462

date: 01/2014

scale: 1:100; 1:20

area: total = 119,0 sq.m.

tel:- (011)892-3958

fax:- (011)892-3958

cell:- 082-458-4839

e-mail:- pbez@pjb-architect.co.za

web:- www.pjb-architect.co.za

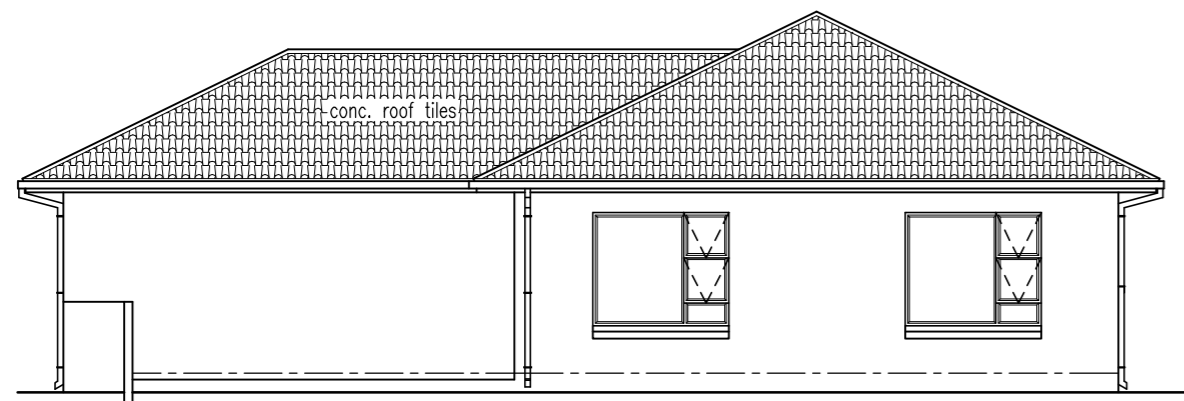

NORTH ELEVATION
scale 1:100

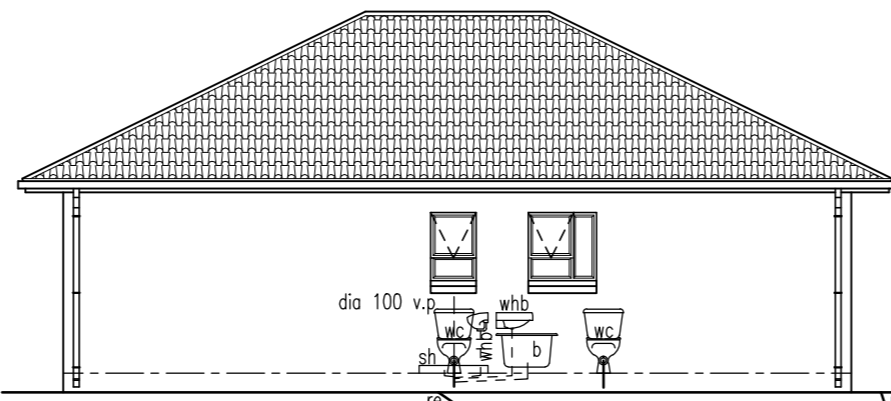

WEST ELEVATION
scale 1:100

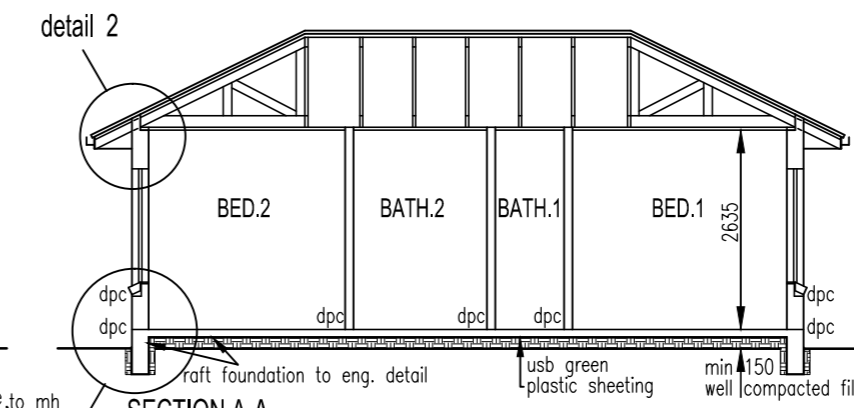

SECTION A-A
scale 1:100

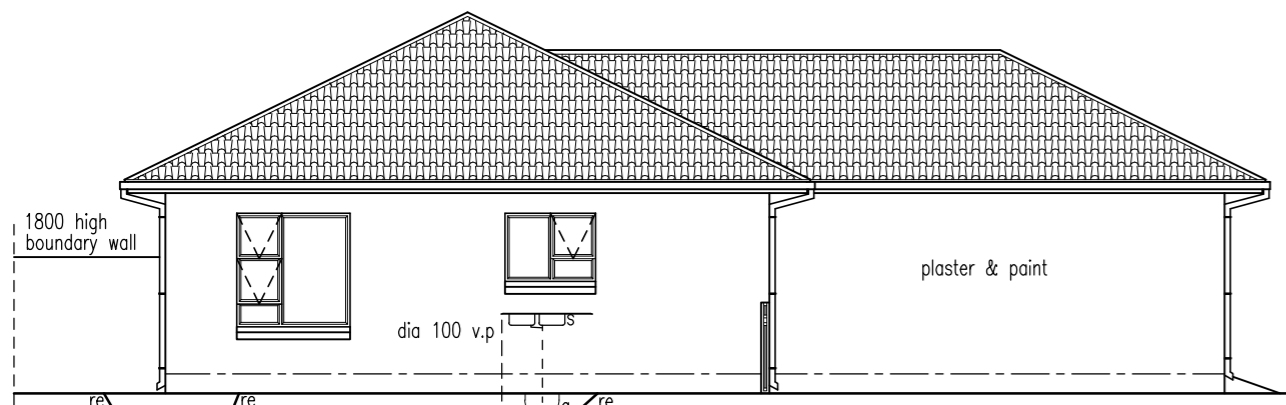

SOUTH ELEVATION
scale 1:100

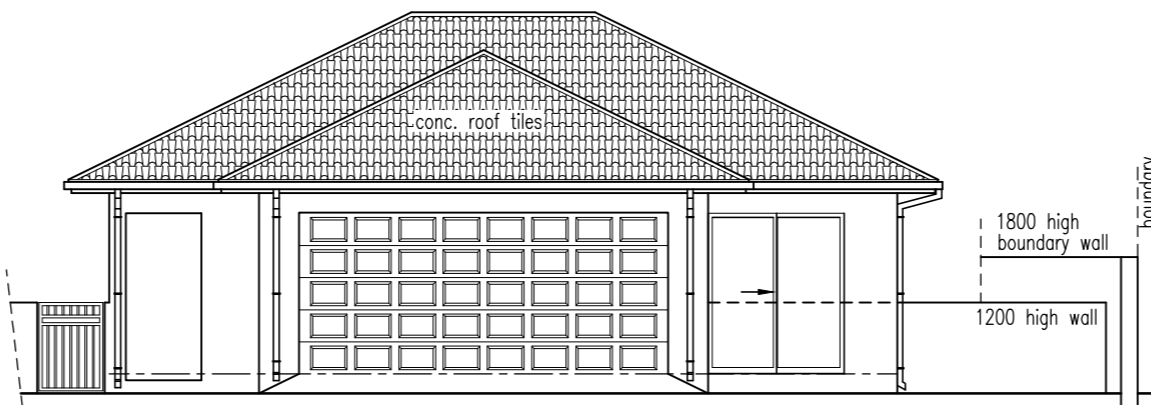

EAST ELEVATION
scale 1:100

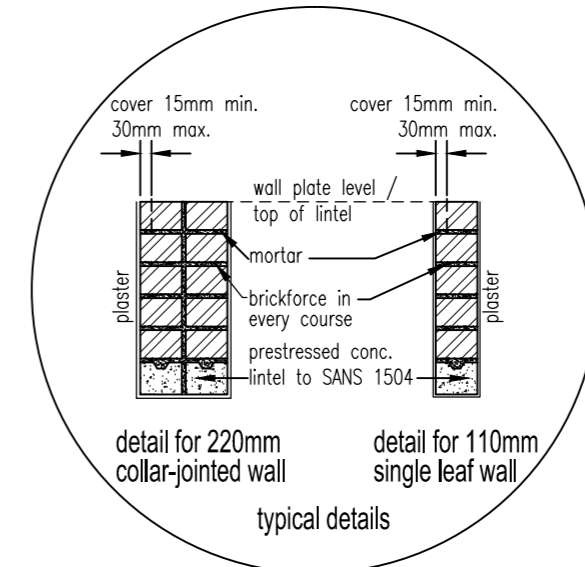

typical details

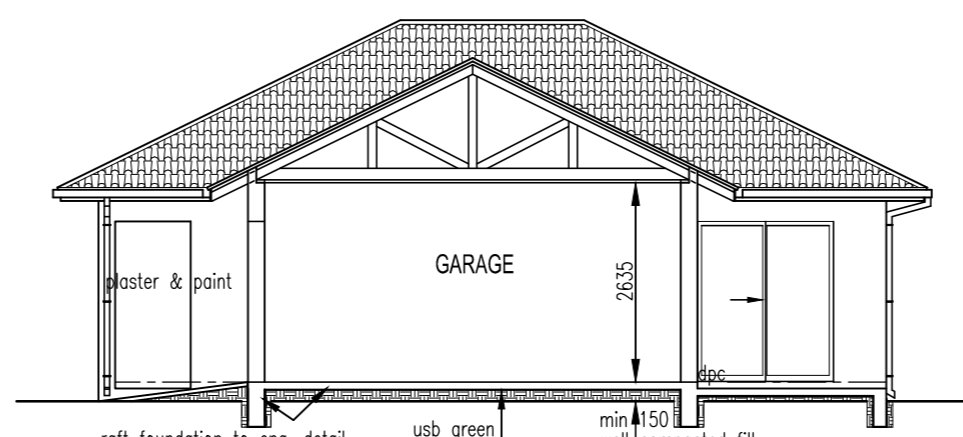

SECTION B-B
scale 1:100

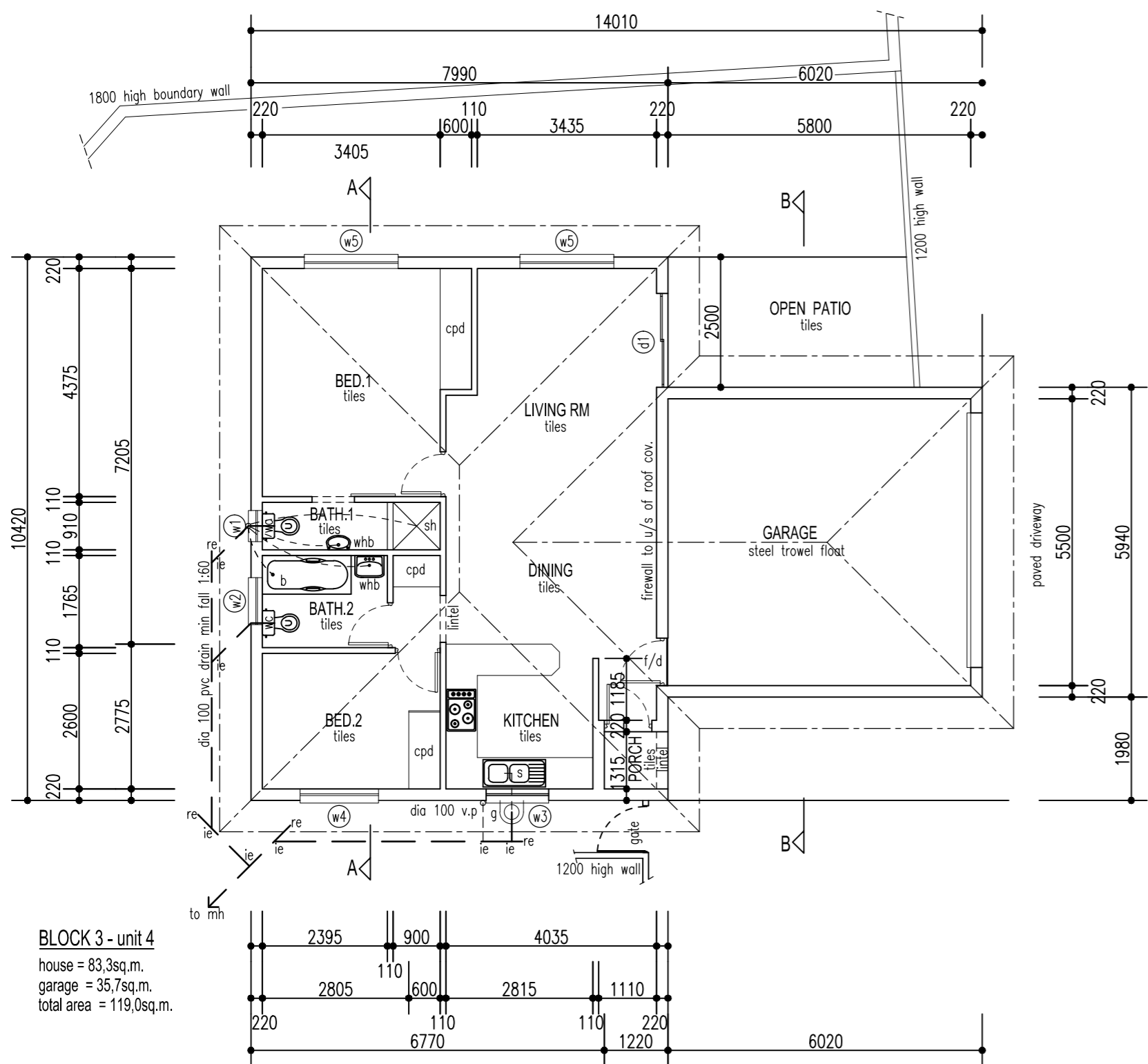

BLOCK 3 - unit 4
house = 83,3sq.m.
garage = 35,7sq.m.
total area = 119,0sq.m.

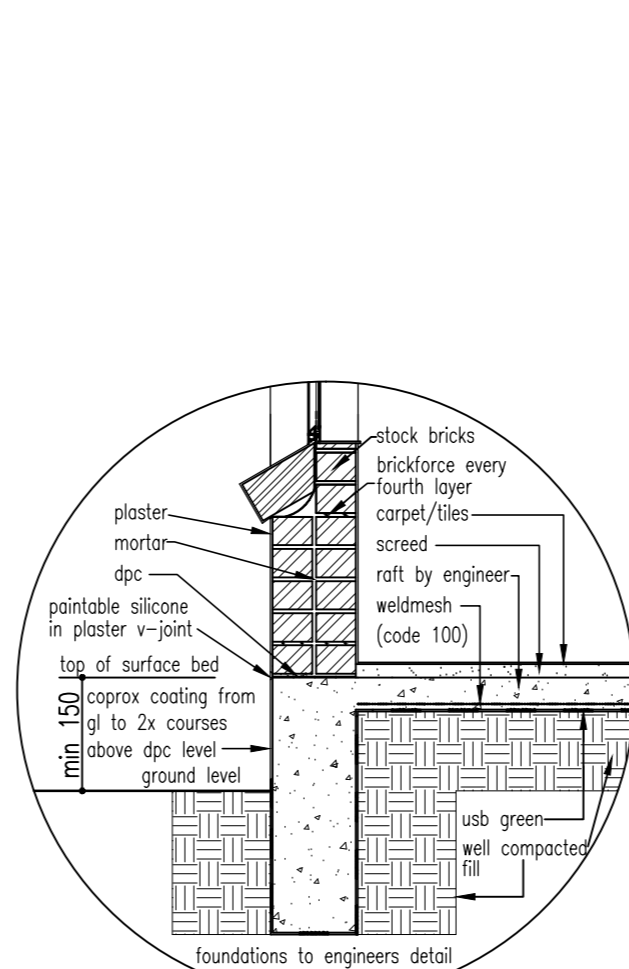

detail 1
scale 1:20

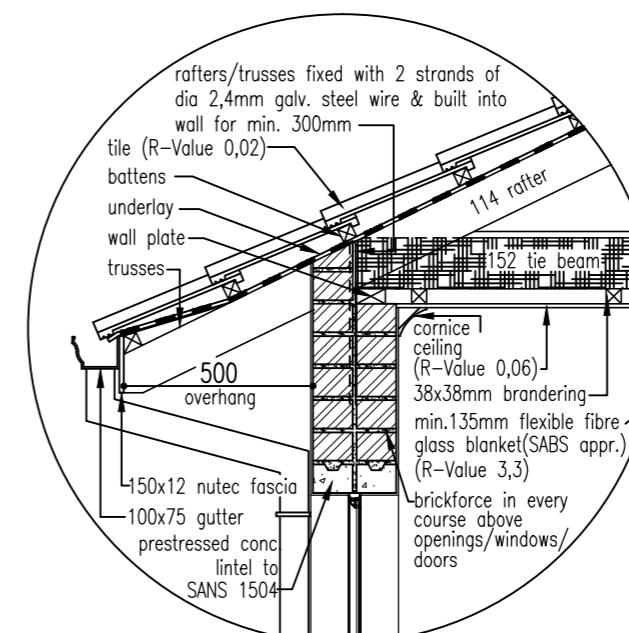

detail 2
scale 1:20